



# ABACO

MODULAR SYSTEM OF  
FITTINGS FOR SHUTTERS



HARDWARE SYSTEMS FOR WINDOWS AND DOORS

## Added strength to tradition

The shutter is more than a mere screen that shuts out the light and protects from the weather.

Whether a shutter or a blind, whether single or multi-sash, we expect it to be also anti-burglar as well as to blend with the style of the building with which it is incorporated, in perfect harmony with its architecture.

To meet these requirements, the shutter must be the result of careful study and design as to all of its components, last but not least the fittings.

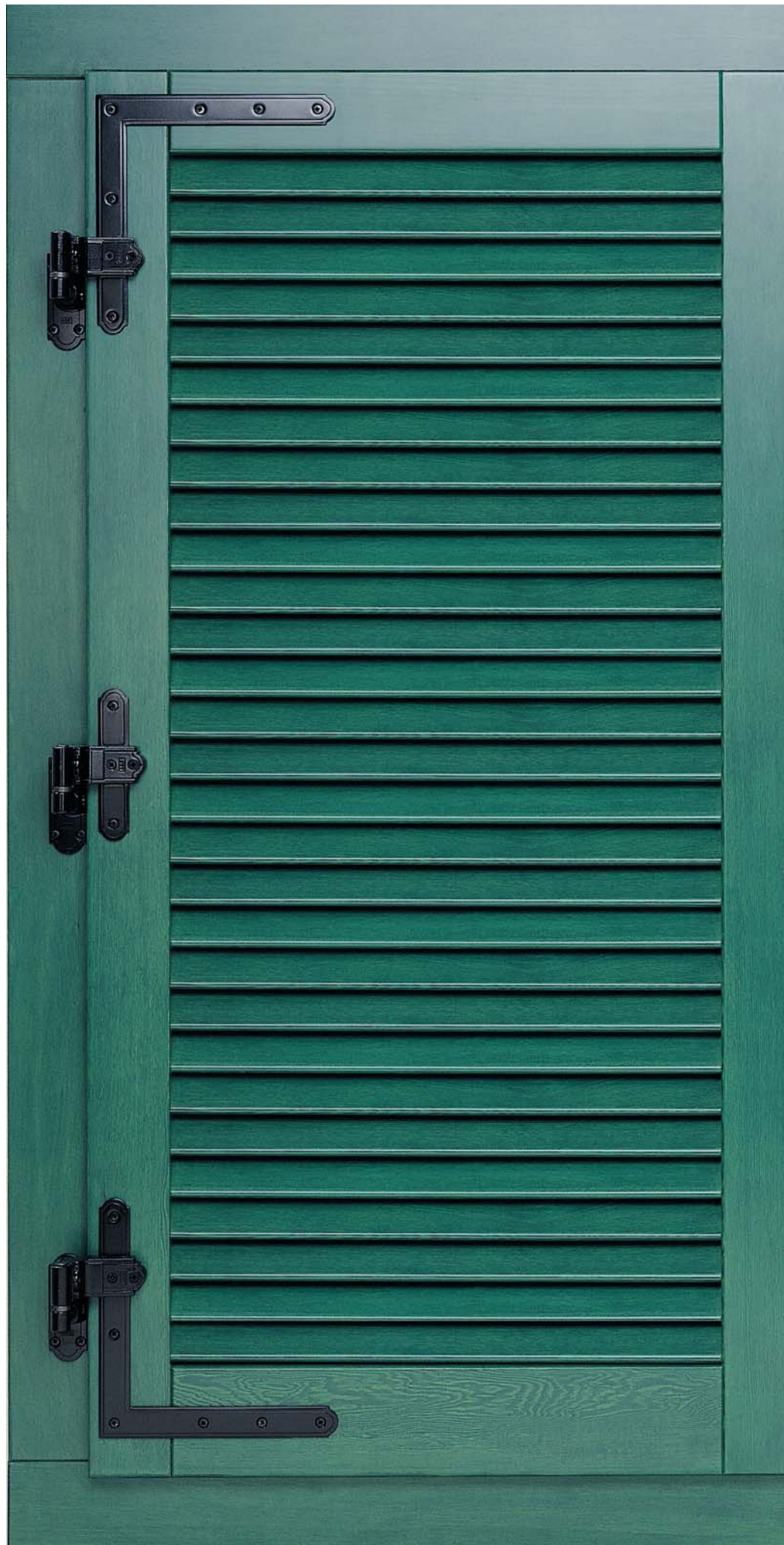



# ABACO

The ideal fittings for shutters made from ...

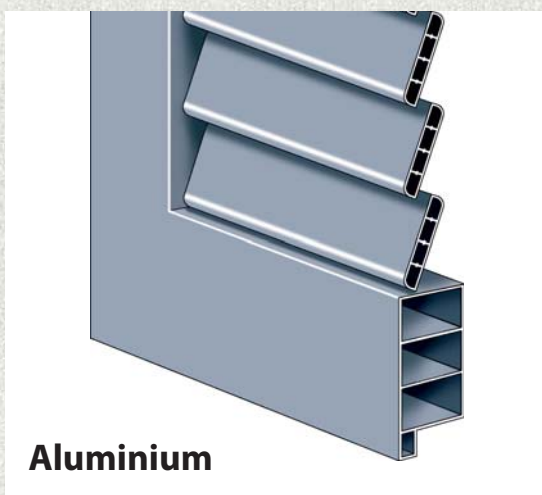
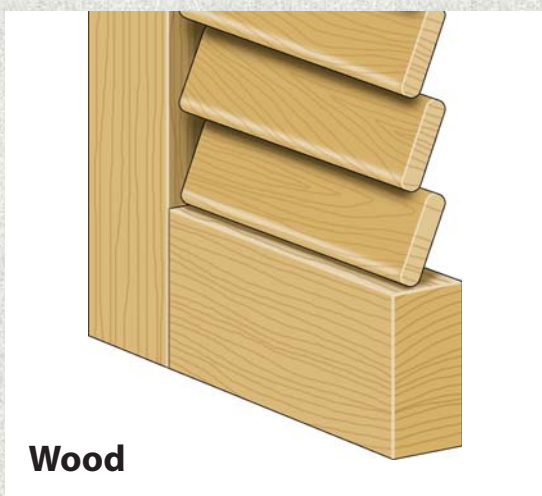



# ABACO

## Simple and effective solutions

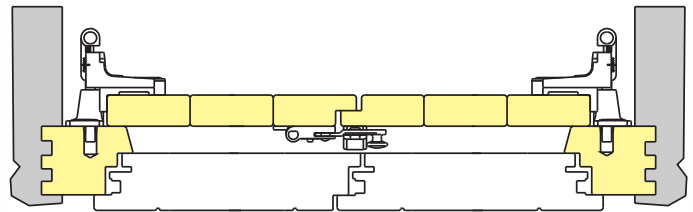

**Shutters with adjustable hinges**

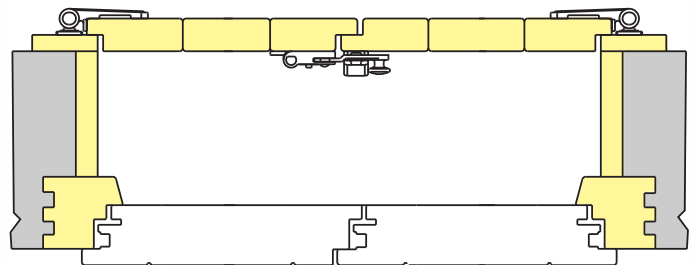

**Shutters on wainscotted reveal**

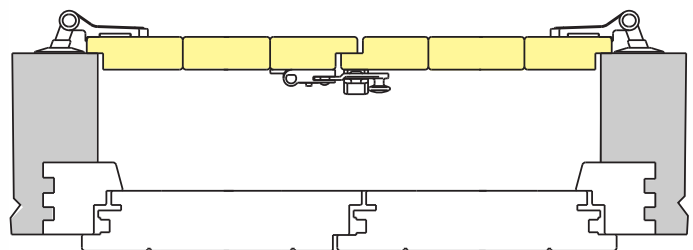

**Wall shutters**

**for any type of construction**

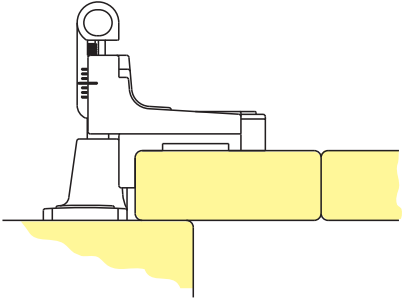

**Overlapped closure**

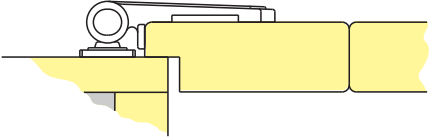

**Rebated closure**

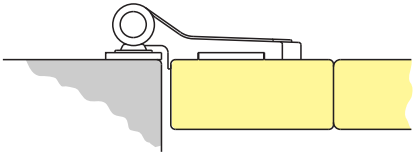

**Flush closure**







# ABACO

## Functional and safe shutters for any opening system

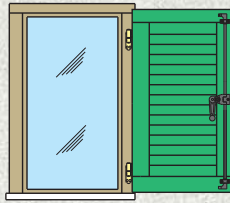

Single shutter.

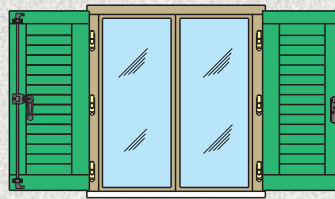

Double-sash shutter.

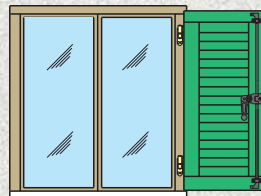

Double-sash folding shutter.

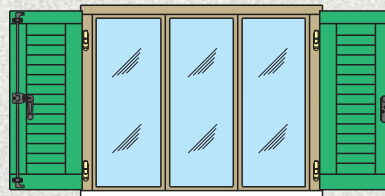

Triple-sash shutter.

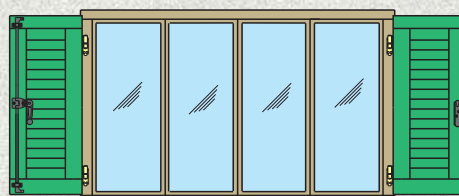

Four-sash folding shutter.





# ABACO

The features of the fittings are indeed an essential to the aesthetics, functionality, safety and dependability of the shutter as a whole. These are the reasons why AGB has developed **ABACO**, the modular system of fittings for shutters that enhances an excellent tradition with innovative and reasonable solutions.

## More combinations with reduced stock

This system consists of various modular components that can be combined according to the different structural requirements. Hinges, connecting plates and brackets are supplied separately. This is in the aim to simplify the storekeeping procedures and yet be able to meet any structural requirement, even at the last minute.

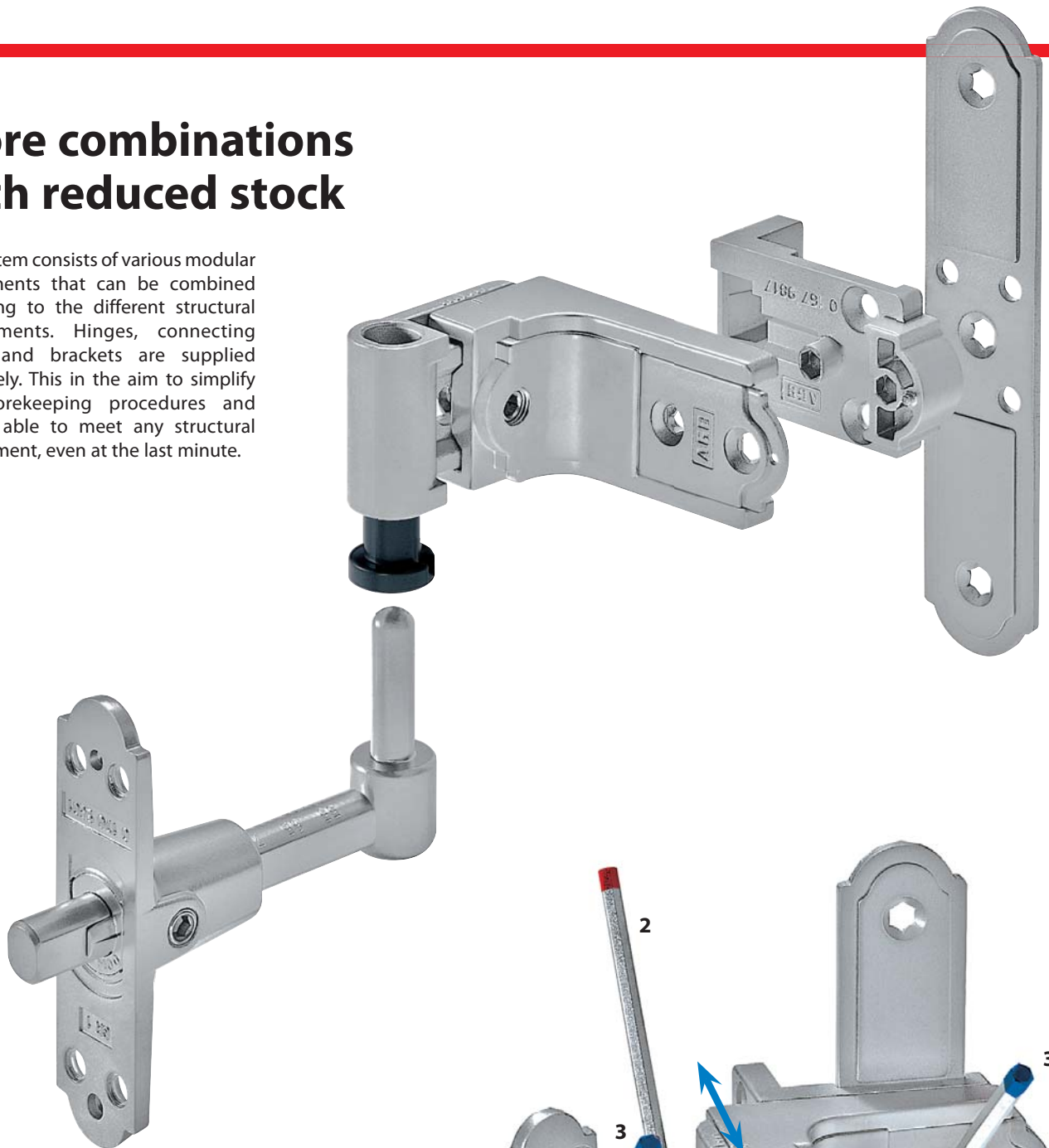

## Just one key for all adjustments

ABACO allows to perform a wide range of adjustments by using just one 4 mm allen key. All adjusting screws are made from stainless steel.

**The side adjustment** of the shutter is performed by acting the key (2).

**The axial adjustment** is performed in two ways:  
 - first by acting on the frame hinge (1), for quick and accurate shutter positioning;  
 - secondly by exerting pressure on the sash hinge (3), on either side, in order to make up for working tolerances or any deformation of the sash.

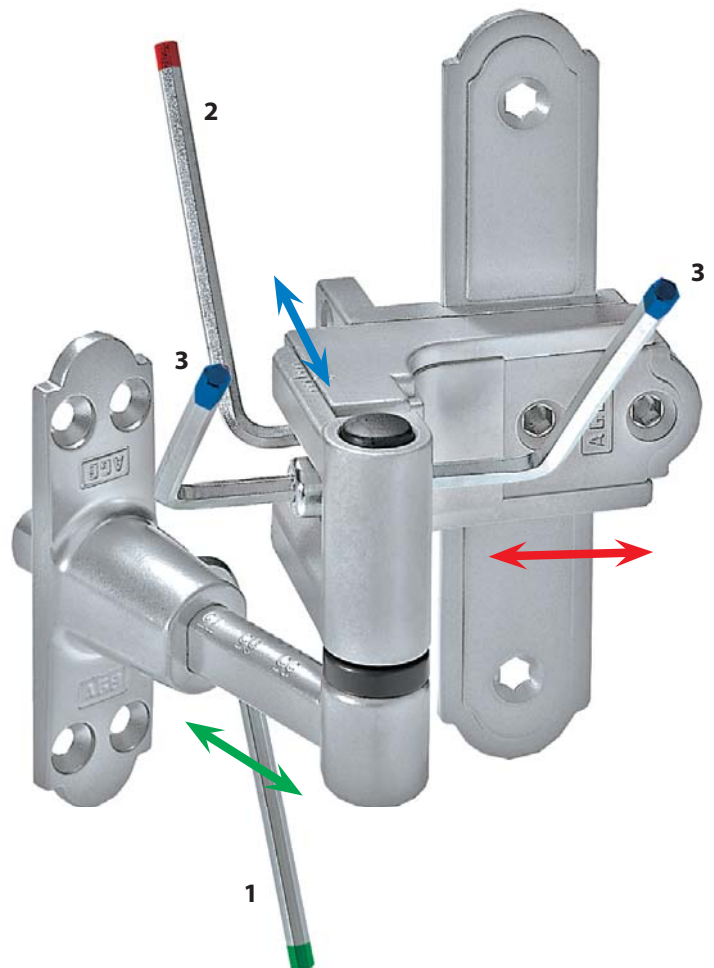



## Easier transportation and installation

One of the advantages offered by the **ABACO** modular system is the possibility to fit the hinges even at the very last minute, on site.

This makes transportation and handling much easier, thanks to the limited space taken up by the shutters.

In addition, by just replacing the hinge during installation you will be able to make up for any differences, even remarkable ones, between the original project and the actual dimensions of the reveals.





# Hi-protection finish

## Powerage

### Withstands any extreme condition

Following collaboration with university research institutes, and with technology developed by one of the major paint producers worldwide – the new **Powerage** finish.



**High corrosion resistance**

**As bright as ever, after prolonged ultraviolet ray exposure**



**Powerage Black and Silver:**  
**2016 hours** in salt spray test without any red rust spot according to EN ISO 9227.

**!** The performances of Powerage finish are guaranteed only if screws with same or higher corrosion resistance are used.

### THREE-LAYER COVER

**Powerage = Phosphatizing + Cataphoresis + Powder coating**

- Powder coating
- Cataphoresis
- Zinc salts phosphatizing

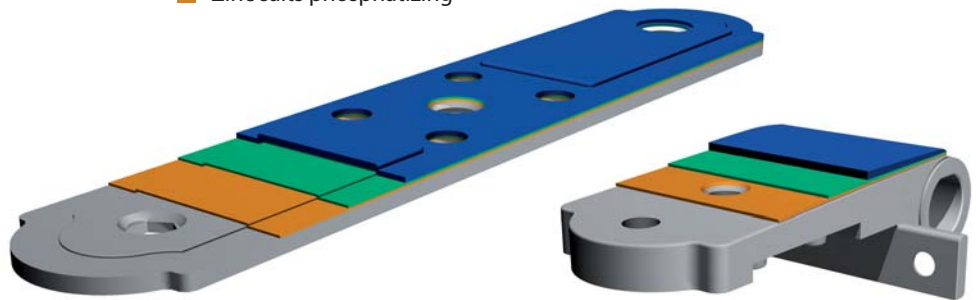

Steel

Zamak

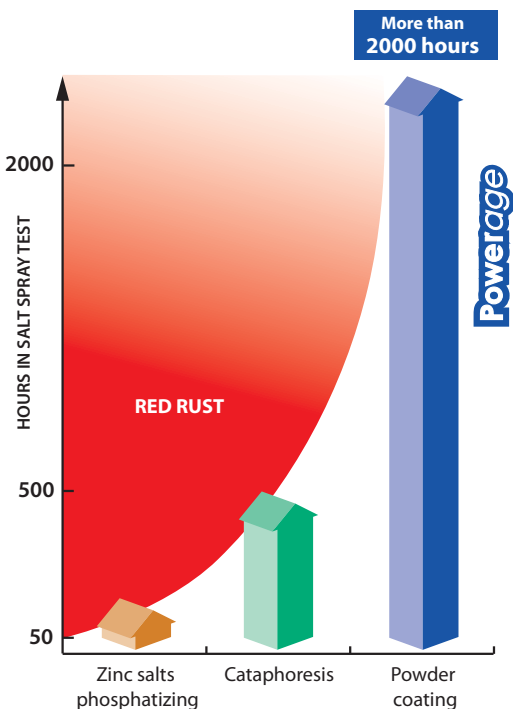

<b>RESISTANCE IN SALT SPRAY TEST</b>	<b>More than 1500 hours</b>	As specified in the UNI EN ISO 9227 regulation, without red rust impacting surfaces in any way whatsoever.
<b>RESISTANCE TO HUMIDITY</b>	<b>More than 1500 hours</b>	As specified in the UNI EN ISO 6270-2 regulation, in constant humidistatic (CH) environment.
<b>RESISTANCE TO AGEING</b>	<b>More than 1000 hours</b>	of exposure in artificial environment, in conformity to UNI EN ISO 11341, variation of brightness of colour less than 50% of initial value (assessment method: according to UNI EN ISO 2813).
	<b>Florida Test 12 months</b>	of exposure in natural environment, in conformity to UNI EN ISO 2810, variation of brightness of colour less than 50% of initial value (assessment method: according to UNI EN ISO 2813).



## ● Sash hinge

The sash hinge is of one type and nono-handed. It can be used in all typologies, in the flush, rebated and overlapped closure systems. It comes in four sizes and must be chosen according to the depth of the wall reveal.

*Extractable bushing of self-lubricating plastics (Hostaform-M): makes the hinge ambidextrous and ensures an extremely smooth movement; prevents rust formation.*

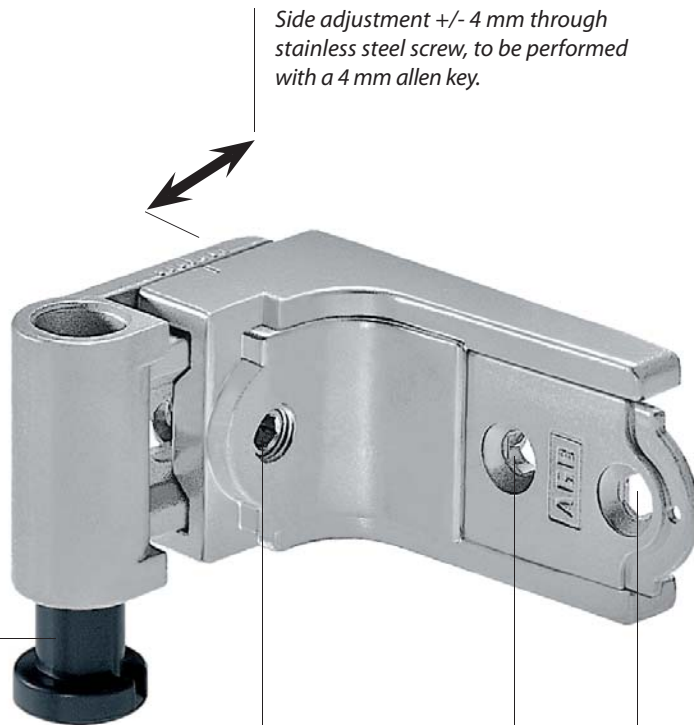

*Side adjustment +/- 4 mm through stainless steel screw, to be performed with a 4 mm allen key.*

*Depth adjustment on both sides of hinge, without impairing the anti-burglar safety of the system.*

*Holes for fitting anti-burglar screws.*

*Adjustment ranges:*  
 Gr. 0 and 1 +/- 6 mm  
 Gr. 2 +/- 10 mm  
 Gr. 3 +/- 12 mm

## ● Connecting plates

The use of just one sash hinge for all types of connections is made possible by four interchangeable connecting plates with dovetail coupling.

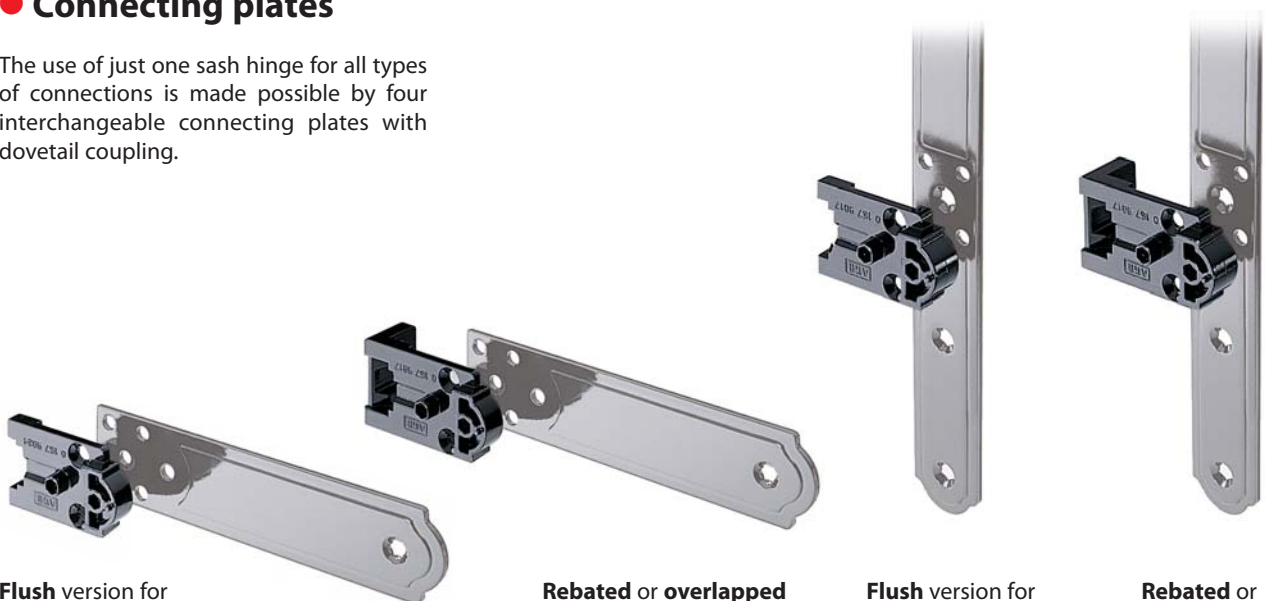

**Flush** version for **horizontal** brackets

**Rebated** or **overlapped** version for **horizontal** brackets

**Flush** version for **corner** and **vertical** brackets

**Rebated** or **overlapped** version for **corner** and **vertical** brackets

## ● Frame hinge

The **ABACO** frame hinge is adjustable and comes in four different sizes.

*Ambidextrous bracket made from die-cast metal alloy. Can be supplied with either narrow plate (25 mm) or large plate (36 mm); various sizes available, to be chosen according to the type of structure and size of the reveal.*

*Rear centering guide for truing up the shank with the bracket.*

*Millimetric scale for accurate adjustment of the hinge axis of rotation.*

*Pivot of pressed steel, diameter 18 mm and pin 9x30 mm.*

*The connection between pivot and shank is made extremely resistant by induction welding.*

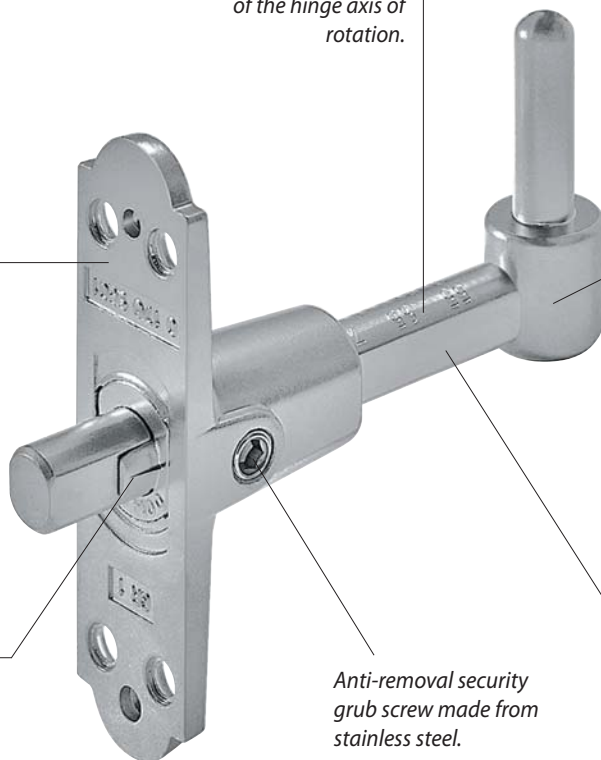

*Steel shank with oval-vertical section that increases the flexural strength.*

## ● Corner brackets

They are used to strengthen the connection between the jamb and rails of the shutter on the hinge side. Particularly suitable for blinds.

They are made from pressed steel and are available in the left-hand side or right-hand side versions, with two coupling positions for the connecting plate: 96 mm and 150 mm.



## ● Horizontal brackets

Their use helps preventing the vertical slats from becoming unstuck and the edge of bulky leaves from dropping.

They are made of pressed steel and come in three different lengths: 160 mm, 245 mm, 330 mm.



## ● Vertical brackets

They are normally used as central bracket in combination with the corner brackets.

They can replace the corner and horizontal brackets in those shutters that do not require structural reinforcements and therefore where the hinges can be secured to the stile only. Available in one version made of pressed steel 28x140x3 mm.





### ● Hinge lock

To be fitted on the lower frame hinges, it holds the sash open to the maximum degree and acts also as anti-lift device. It can be released easily with just one hand.

The sash can be installed in any open position, except at 180° (locked position).

The Kit includes the spring loaded bumper with rubber pad.



### ● Wall catch for shutters

Holds the sash wide open, securing it to the wall. Although it is particularly suitable for doors, thanks to its small size the stricker can be fitted also on the bottom rail of any shutter.

The height of stricker can be adjusted (+/- 6 mm), ensuring correct use of the catch at all times.

For insulating panels application also available.



### ● Wall catch with handle

The handle is installed in an easily reachable position on the sash front: with just one hand the shutter can be un-hooked and pulled.

The wall catch with handle is the proper solution for the unhook and the movement of the shutters installed on balcony doors without exit.

For insulating panels application also available.



### ● Central hinge for folding shutters

It is used in the case of multi-sash folding shutters. Two versions available: **In line:** for leaves folding towards the outside; the hinge is fitted on the inner side.

**Off-set:** for inside-folding leaves; the hinge is fitted on the outer side.



### ● Hinges with low neck

To be used in combination with pintles. Available in four different models, to be chosen according to:

- the coupling - with corner and vertical brackets or with horizontal brackets;
- the height of hinge neck, either 0 or 15 mm.



### ● Pintles

They are used in case of limited depth of the reveal or when the frame is flush with the exterior wall. Two versions available:

**fixed:** distance between pivot and base centers: 12, 15, 18, 20, 22 mm;

**adjustable:** distance between pivot and base centers can be adjusted between 12 and 45 mm by means of a threaded shank M12x70.



## ● Bumpers

Available separately in the following version: single rubber piece (rigid); spring-loaded with rubber pad. Height: 25 the rubber bumpers, 27 mm the spring-loaded ones, both with  $\varnothing$  28 mm.

Superimposable shims measuring 5 mm each available for special applications.



## ● Shim for hinges

To be used as a compensating shim in cases where the structure of the shutter allows to secure the hinge directly to the sash without brackets.

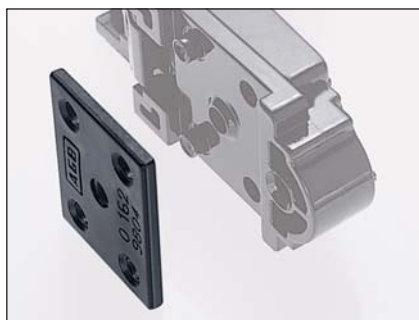

## ● Anti-burglar screws

Stainless steel screws in eight different sizes. The smooth outer head and hexagonal sub-head make it impossible to unscrew them from the outside when the shutter is closed. They are fitted from the inside by means of a threaded bush suitable for a 4 mm allen key.





## ● Locking sets

**1** The handle is not pre-assembled. It can be positioned at any height.

**2** In double sash systems, the handle ensures optimum safety also in the half-open position.

The stay of the second sash has been so designed that it will not damage the painting of the shutter during opening and closing.

**3** Closing hooks: their special profile ensures optimum resistance to any deformation of the casing due to humidity or temperature changes. The sash pressure can be adjusted by acting on the closure pins with a 4 mm Allen key.

**4** Top- and bottom-expansion vertical lock systems, complete with pit rotation compensating devices.

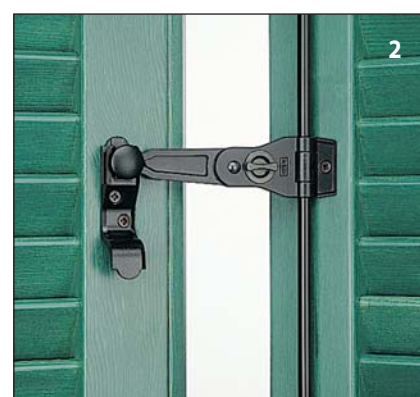



HARDWARE SYSTEMS FOR WINDOWS AND DOORS

Alban Giacomo SpA  
Via A. de Gasperi, 75  
36060 Romano d'Ezzelino (VI) Italy  
Tel. +39 0424 832 832  
[www.agb.it](http://www.agb.it) - [info@agb.it](mailto:info@agb.it)